

HF02 (formal indication LEX35A, B or C), is a temperature sensor than can be used for sensing heat flux or thermal radiation in an outdoor environment. It is designed in particular for flare radiation monitoring and activation of alarm systems. The design is certified for use in an explosive environment, and can cope with radiation levels up to 15.000 W/m².

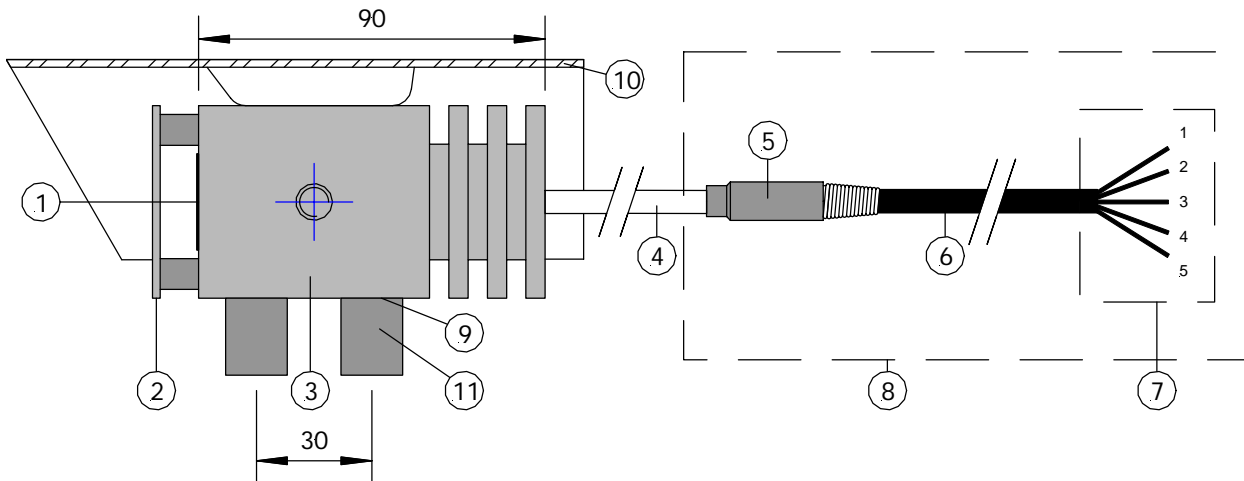

Figure 1 HF02 overview: HF02 consists of a sensor (1) with both temperature and heat flux output, a body (3), a radiation screen (2) and radiation / rain screen (10) to protect the sensor against the environment, a mineral insulated cable (4), potting (5), a plastic cable (6), mounting holes (3/8 UNC) (9) and spacers (11). Area 8 must be between -20 and +70 degrees C, and area 7 must be certified according to the area of installation of the connection box, both within the responsibility of the user. All dimensions are in mm.

INTRODUCTION

HF02 is intended to be used as a sensor in alarm systems in case of possible high thermal radiation exposure. A typical application is close to flares. A common assumption is that the heat flux level for a safe environment for personnel must not exceed 5 kW/m² (or 1500 BTU/hr ft²), or otherwise an alarm is activated.

A typical alarm system will include multiple sensors, each aimed at the main source of radiation.

The sensor in HF02 will measure the heat flux to the black (fully absorbing) surface of the sensor itself. It thus provides a reasonable measure of the worst-case effective exposure for personnel and equipment from the particular direction that the sensor aims at, at the location of the sensor. As the detector is essentially open (no windows) the measurement is influenced by wind in much the same way as any exposed surface; increased wind reduces the effective exposure and leads to reduced measured flux.

The rain- and radiation screen act to locally reduce the effect of wind, preventing the false indication of a safe situation. Rain on the detector can also lead to cooling and a reduction of the measured flux. This again could lead to a false indication of a safe situation. The rain screen will in most cases prevent this from happening.

To perform a representative measurement, the sensor temperature should be as close as possible to ambient temperature. A secondary purpose of the radiation screen (in combination with cooling fins) is to reduce heating of the sensor.

(Continued on the next page)

HF02 INTRODUCTION (CONTINUED)

It can be debated if compensation or correction of the measurement for the influences of solar radiation is necessary. As the maximum solar radiation level is about 1.3 kW/m², it is certainly significant. It is however not part of the source that is usually monitored.

On the one hand the safety is determined by the total heat flux that personnel or material is exposed to.

On the other hand the determination of the contribution of solar radiation is virtually impossible because the solar source is moving. Solar radiation might therefore have its maximum in a direction that is not seen by the detector.

The typical solution is to accept that solar radiation is part of the measurement in case that it is within the sensor's field of view, and to neglect it if it is not within the sensor's field of view.

Using HF02 is easy. For readout one needs an accurate voltmeter that works in the millivolt range. To calculate the heat flux, the voltage must be divided by the sensitivity; a constant that is supplied with each individual instrument.

Temperature is monitored as a redundant safety precaution. In case the sensor goes above a certain temperature level, say 70 °C, it is recommended to take action.

CALIBRATION / QUALITY ASSURANCE

Verification of the stability of the total sensor can be performed by comparison to a portable heat flux sensor.

MORE INFORMATION / OPTIONS

Extended cable. Standard length for mineral insulated cable as well as plastic cable is 3 m. Both can be extended up to 200 m.

Sensitivity: In case the electronics accuracy is not sufficient, the sensitivity of the heat flux measurement can be increased.

Shielding options: sensor and mineral insulated cable connected to shield is standard. Not connected can be offered as an option.

Compensation and calibration: Hukseflux can provide solar radiation sensors (for solar radiation compensation) as well as portable heat flux sensors type HF03 (for calibration).

HF02 SPECIFICATIONS

Primary measurements:	heat flux in the plane of the sensor surface in kW/m ² and sensor temperature in °C
Range (heat flux):	0 to 15 kW/m ²
Output (heat flux):	0.5 mV/ (kW/m ²)
Calibration traceability:	NIST
Temperature:	Thermocouple KX, ANSI MC96.1-1982
Temperature range (total sensor including mineral insulated cable):	-50 to +150 °C
Short term exposure (total sensor including mineral insulated cable):	to 500 °C
Temperature range (plastic cable):	-20 to +70 °C
Formal sensor name:	LEX35A, LEX35B or LEX35C
EC type examination certificate:	II 2 G EEx d IIC T6
Materials used:	Stainless steel, duplex steel, PVC
Cable (standard version):	3 m mineral insulated 6 mm OD, 3 m PVC. Both extendable
Weight (standard version):	2.5 kg
Protection class:	IP 67
Important safety notes:	Area 8 must be between -20 and +70 °C, and area 7 must be certified, both within the responsibility of the user. Regular inspection of the sensor surface is recommended to verify if it has a free field of view. Recalibration is recommended every year by comparison to a portable heat flux sensor.
Electrical Data:	U max 5V, I max 5 mA
Lex35A:	Sensor insulated, ground in connection box
Lex35B:	Shield connected to sensor
Lex35C:	No plastic cable, all other as Lex 35B