

The HF01 high temperature heat flux sensor is used to perform measurement of heat fluxes and surface temperature at high temperatures. The same technology can be used to manufacture heat flux sensors for different applications.

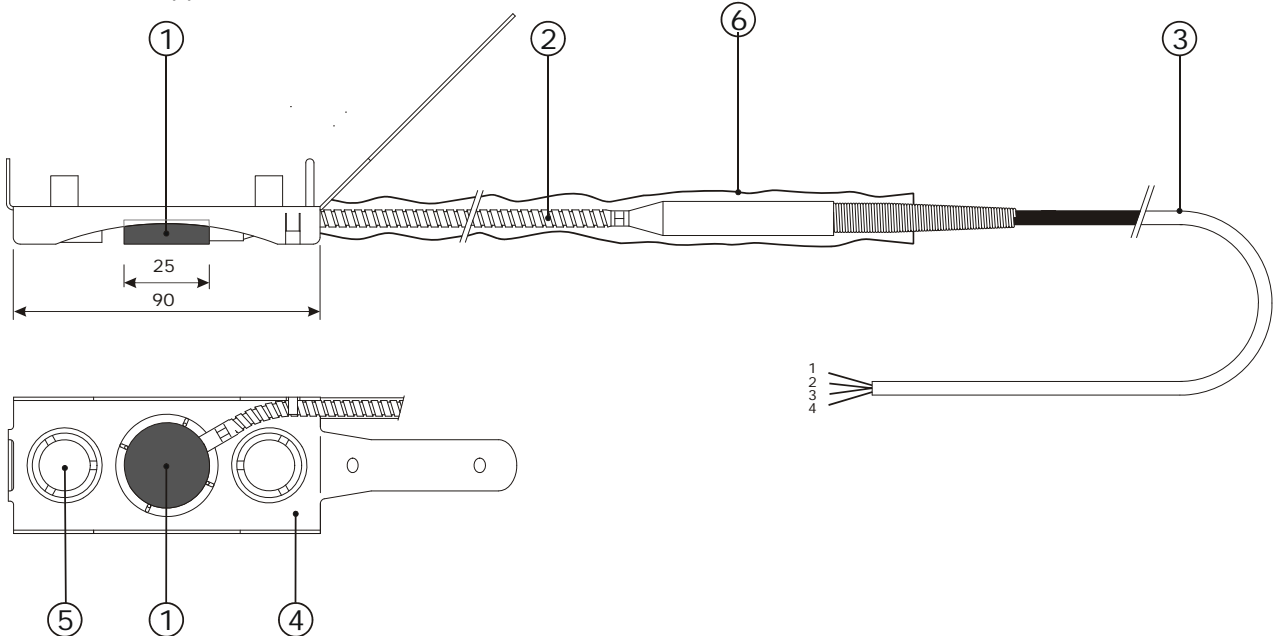

Figure 1 HF01. The heat flux sensor (1), connected to a metal sheathed cable with flexible hose (2) and teflon extension cable (3). The frame (4) with magnets (5) is an option which is intended for temporary mounting on iron furnace walls. The silicone sleeve (6) protects the flexible hose. Dimensions are in mm.

INTRODUCTION

The HF01 has been designed for studies of the energy balance of industrial furnaces, boilers, fluidised beds, distillation columns and ovens.

The actual sensor is incorporated in a fully stainless steel housing.

The first part of the cabling is metal sheathed, with an additional metal protection hose. The sensor as well as the metal cable can withstand temperatures up to 800 degrees C.

The extension cable is made of Teflon. To avoid leakage of current, a silicon sleeve is placed over the metal sheathed cable.

The sensor output consists of a heat flux signal (microvolt analog signal) and a temperature signal (type K thermocouple). The thermocouple is used to measure surface temperature, and at the same time sensor temperature.

Advantages of HF01 relative to competing models are:

- robust, in particular at high temperatures
- fast response time, so reduced experiment time
- low thermal resistance; improved measurement accuracy

SUGGESTED USE

- Studies of aluminium melting furnaces

MORE INFORMATION / OPTIONS

Optional: extended cable, metal frame with magnets (MF01).

Alternative designs: Hukseflux is specialised in heat flux sensor design. For different applications special models can be constructed.

HF01 SPECIFICATIONS

Sensitivity heat flux (nominal):	0.5 10^{-3} mV/W.m ⁻² @ 90 deg C
Working range:	0.05 to 50 kW.m ⁻²
Temperature range sensor and metal sheathed cable:	-30 to +800 °C
Temperature range teflon cable:	-30 to +240 °C
Optional items:	Metal frame with magnets (MF01) (to 550 °C only) cable extension
Protection sensor / cable:	IP 65
Metal cable length:	900 mm
Teflon cable length:	3500 mm
Silicon sheet	1000 mm (optional)